



WELCO VALVE



**API602 Small Forged Steel
Gate,Globe & Check Valves**

www.cnvalveco.com

Applicable Standards:

- STEEL GATE VALVES, API 602
- STEEL VALVES, ASME B16.34
- FACE TO FACE, MANUFACTURER STANDARD
- FACE TO FACE, FLANGED, ASME B16.10
- END FLANGES, ASME B16.5
- BUTTWELDING ENDS, ASME B16.25
- SOCKET-WELDING ENDS, ASME B16.11
- SCREWED ENDS, ASME B1.20.1
- INSPECTION AND TEST, API 598

Design descriptions:

- OUTSIDE SCREW AND YOKE (OS&Y)
- BOLTED BONNET
- CHOICE OF WB, WELDED BONNET
- SINGLE WEDGE, FULLY GUIDED
- RENEWABLE SEAT RINGS
- YOKE INTEGRAL WITH BONNET
- RISING STEM AND NON-RISING HANDWHEEL
- SW, SOCKET-WELDING ENDS
- SC, SCREWED ENDS
- BW, BUTTWELDING ENDS
- FLANGED ENDS

Materials of parts

No	Part Name	ASTM Materials		
		C-Si	16Cr-12Ni-2Mo	1 1/4Cr-1/2Mo-Si
1	Body	A105	A182-F316	A182-F11
2	Bonnet	A105	A182-F316	A182-F11
3	Wedge	A182-F6a	A182-F316	A182-F6a+HF
4	Stem	A276-410	A276-316	A276-410
5	Seat Ring	A276-410	A182-F316	A276-410+HF
6	Bonnet Gasket ¹⁾	Graphite+304	Graphite+316	Graphite+304
7	Bonnet Stud	A193-B7	A193-B8M	A193-B16
8	Packing	Graphite		
9	Gland	A276-410	A276-316	A276-410
10	Gland Flange	A105	A182-F316	A182-F11
11	Eyebolt Pin	A276-410	A276-316	A276-410
12	Eyebolt	A193-B7	A193-B8M	A193-B16
13	Eyebolt Nut	A194-2H	A194-8M	A194-2H
14	Yokesleeve	A276-410		
15	Handwheel	Malleable Iron		
16	Handwheel nut	Carbon Steel		

Note: 1) spiral wound construction

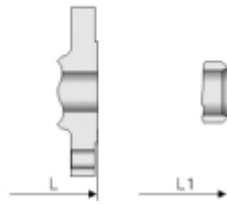
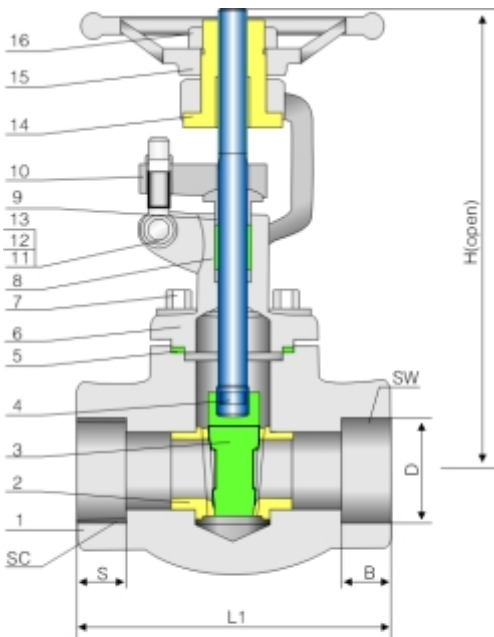

Dimensional datas

NPS DN	Unit	L1 ¹⁾	L(Flanged Ends)			d	SW		SC	H(open)	D0	WT ²⁾ (kg)	
			150Lb	300Lb	600Lb		D	B					
3/8	in	3.12	4.00	5.50	6.50	0.394	0.693	0.378	3/8	0.540	6.00	4.00	4.5/4
10	mm	79	102	140	165	10	17.6	9.6		13.6	151	100	
1/2	in	3.12	4.25	5.50	6.50	0.394	0.858	0.378	1/2	0.535	6.00	4.00	5.1/4
15	mm	79	108	140	165	10	21.8	9.6		13.6	151	100	
3/4	in	3.62	4.62	6.00	7.50	0.531	1.067	0.500	3/4	0.547	6.25	4.00	8.2/4.3
20	mm	92	117	152	190	13.5	27.1	12.7		13.9	158	100	
1	in	4.38	5.00	6.50	8.50	0.709	1.331	0.500	1	0.681	7.25	5.00	10.5/6.6
25	mm	111	127	165	216	18	33.8	12.7		17.3	185	125	
1 1/4	in	4.75	5.50	7.00	9.00	0.945	1.677	0.500	1 1/4	0.709	9.38	6.25	12.4/9.5
32	mm	120	140	178	229	24	42.6	12.7		18	239	160	
1 1/2	in	4.75	6.50	7.50	9.50	1.181	1.917	0.500	1 1/2	0.724	9.50	6.25	20.1/11
40	mm	120	165	190	241	30	48.7	12.7		18.4	243	160	
2	in	5.50	7.00	8.50	11.50	1.437	2.406	0.626	2	0.756	11.00	7.00	28/14.5
50	mm	140	178	216	292	36.5	61.1	15.9		19.2	279	180	

Notes: 1) BW, SW or SC.
2) 600Lb-RF/800Lb--(BW/SW/SC)

Forged Steel Globe Valve 800Lb



Applicable Standards:

- STEEL GLOBE VALVES, API 602
- STEEL VALVES, ASME B16.34
- FACE TO FACE, MANUFACTURER STANDARD
- FACE TO FACE, FLANGED, ASME B16.10
- END FLANGES, ASME B16.5
- BUTTWELDING ENDS, ASME B16.25
- SOCKET-WELDING ENDS, ASME B16.11
- SCREWED ENDS, ASME B1.20.1
- INSPECTION AND TEST, API 598

Design descriptions:

- OUTSIDE SCREW AND YOKE (OS&Y)
- BOLTED BONNET
- CHOICE OF WB, WELDED BONNET
- LOOSE DISC, CHOICE OF PLUG OR BALL
- SEAT RINGS INTEGRAL WITH BODY
- YOKE INTEGRAL WITH BONNET
- RISING STEM AND HANDWHEEL
- HORIZONTAL SERVICE
- SW, SOCKET-WELDING ENDS
- SC, SCREWED ENDS
- BW, BUTTWELDING ENDS

Materials of parts

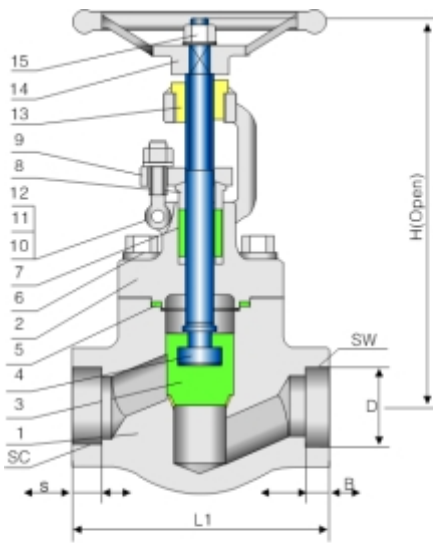

No	Part Name	ASTM Materials		
		C-Si	16Cr-12Ni-2Mo	1 1/4Cr-1/2Mo-Si
1	Body	A105	A182-F316	A182-F11
2	Bonnet	A105	A182-F316	A182-F11
3	Disc	A182-F6a	A182-F316	A182-F6A+HF
4	Stem	A276-410	A276-316	A276-410
5	Bonnet Gasket ²⁾	Graphite+304	Graphite+316	Graphite+304
6	Bonnet Stud	A193-B7	A193-B8M	A193-B16
7	Packing	Graphite		
8	Gland	A276-410	A276-316	A276-410
9	Gland Flange	A105	A182-F316	A182-F11
10	Eyebolt Pin	A276-410	A276-316	A276-410
11	Eyebolt	A193-B7	A193-B8M	A193-B16
12	Eyebolt Nut	A194-2H	A194-8M	A194-2H
13	Yokesleeve	A276-410		
14	Handwheel	Malleable Iron		
15	Handwheel Nut	Carbon Steel		

Note: 1) seat integral with body
2) spiral wound construction

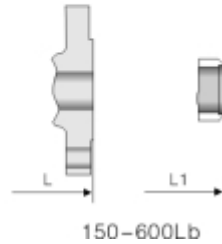

Dimensional datas

NPS DN	Unit	L1 ¹⁾	L(Flanged Ends)			d	SW		SC	H(open)	D0	WT ²⁾ (kg)	
			150Lb	300Lb	600Lb		D	B					
3/8	in	3.12	4.00	6.00	6.50	0.354	0.693	0.378	3/8	0.540	6.50	4.00	3.8/2.8
10	mm	79	102	152	165	9	17.6	9.6		13.6	164	100	
1/2	in	3.12	4.25	6.00	6.50	0.354	0.858	0.378	1/2	0.535	6.50	4.00	5.6/3.4
15	mm	79	108	152	165	9	21.8	9.6		13.6	164	100	
3/4	in	3.62	4.62	7.00	7.50	0.512	1.067	0.500	3/4	0.547	6.50	4.00	7.8/4.7
20	mm	92	117	178	190	13	27.1	12.7		13.9	164	100	
1	in	4.38	5.00	8.00	8.50	0.689	1.331	0.500	1	0.681	8.00	5.00	12.5/9.2
25	mm	111	127	203	216	17.5	33.8	12.7		17.3	203	125	
1 1/4	in	4.75	5.50	8.50	9.00	0.906	1.677	0.500	1 1/4	0.709	8.88	6.25	17/10.5
32	mm	120	140	216	229	23	42.6	12.7		18	224	160	
1 1/2	in	6.00	6.50	9.00	9.50	1.142	1.917	0.500	1 1/2	0.724	10.25	6.25	23.5/13.3
40	mm	152	165	229	241	29	48.7	12.7		18.4	260	160	
2	in	6.75	8.00	10.50	11.50	1.378	2.406	0.626	2	0.756	11.88	7.00	38.8/18.9
50	mm	172	203	267	292	35	61.1	15.9		19.2	300	180	

Notes: 1) BW, SW or SC.
2) 600Lb-RF/800Lb--(BW/SW/SC).

Applicable Standards:

- STEEL CHECK VALVES, API 602
- STEEL VALVES, ASME B16.34
- FACE TO FACE, MANUFACTURER STANDARD
- FACE TO FACE, FLANGED, ASME B16.10
- END FLANGES, ASME B16.5
- BUTTWELDING ENDS, ASME B16.25
- SOCKET-WELDING ENDS, ASME B16.11
- SCREWED ENDS, ASME B1.20.1
- INSPECTION AND TEST, API 598

Design descriptions:

- BOLTED COVER
- CHOICE OF WB, WELDED COVER
- SEAT RINGS TYPE
- SEAT RINGS INTEGRAL WITH BODY OF LIFT
- HORIZONTAL OR VERTICAL SERVICE
- SW, SOCKET-WELDING ENDS
- SC, SCREWED ENDS
- BW, BUTTWELDING ENDS
- FLANGED ENDS

Materials of parts

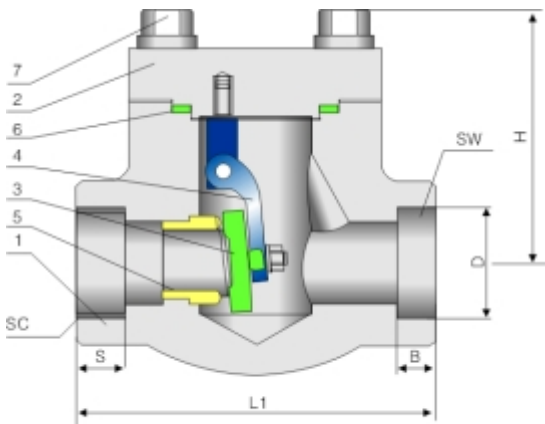

No	Part Name	ASTM Materials		
		C-Si	16Cr-12Ni-2Mo	1 1/4Cr-1/2Mo-Si
1	Body	A105	A182-F316	A182-F11
2	Cover	A105	A182-F316	A182-F11
3	Disc	A182-F6a	A182-F316	A182-F6A+HF
4	Hinge	A276-410	A276-316	A276-410
5	Seat	A276-410	A182-F316	A276-410+HF
6	Gasket ²⁾	Graphite+304	Graphite+316	Graphite+304
7	Stud	A193-B7	A193-B8M	A193-B16

Note: 1) lift type check valve seat ring integral with body.
2) spiral wound construction.

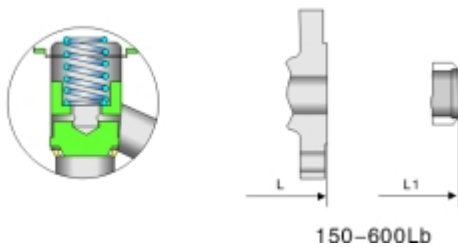

Dimensional datas

NPS DN	Unit	L1 ¹⁾	L(Flanged Ends)			d	SW		SC		H	WT ²⁾ (kg)
			150Lb	300Lb	600Lb		D	B	NPT	S		
3/8	in	3.12	4.00	6.00	6.50	0.354	0.693	0.378	3/8	0.540	2.40	3.8/2.8
10	mm	79	102	152	165	9	17.6	9.6		13.6	61	
1/2	in	3.12	4.25	6.00	6.50	0.354	0.858	0.378	1/2	0.535	2.40	5.6/3.4
15	mm	79	108	152	165	10	21.8	9.6		13.6	61	
3/4	in	3.62	4.62	7.00	7.50	0.512	1.067	0.500	3/4	0.547	2.40	7.8/4.7
20	mm	92	117	178	190	13	27.1	12.7		13.9	61	
1	in	4.38	5.00	8.00	8.50	0.689	1.331	0.500	1	0.681	3.07	12.5/9.2
25	mm	111	127	203	216	17.5	33.8	12.7		17.3	78	
1 1/4	in	4.75	5.50	8.50	9.00	0.906	1.677	0.500	1 1/4	0.709	3.31	17/10.5
32	mm	120	140	216	229	23	42.6	12.7		18	84	
1 1/2	in	4.75	6.50	9.00	9.50	1.142	1.917	0.500	1 1/2	0.724	10.25	23.5/13.3
40	mm	120	165	229	241	30	48.7	12.7		18.4	3.98	
2	in	5.50	8.00	10.50	11.50	1.378	2.406	0.626	2	0.756	4.72	38.8/18.9
50	mm	140	203	267	292	35	61.1	15.9		19.2	120	