

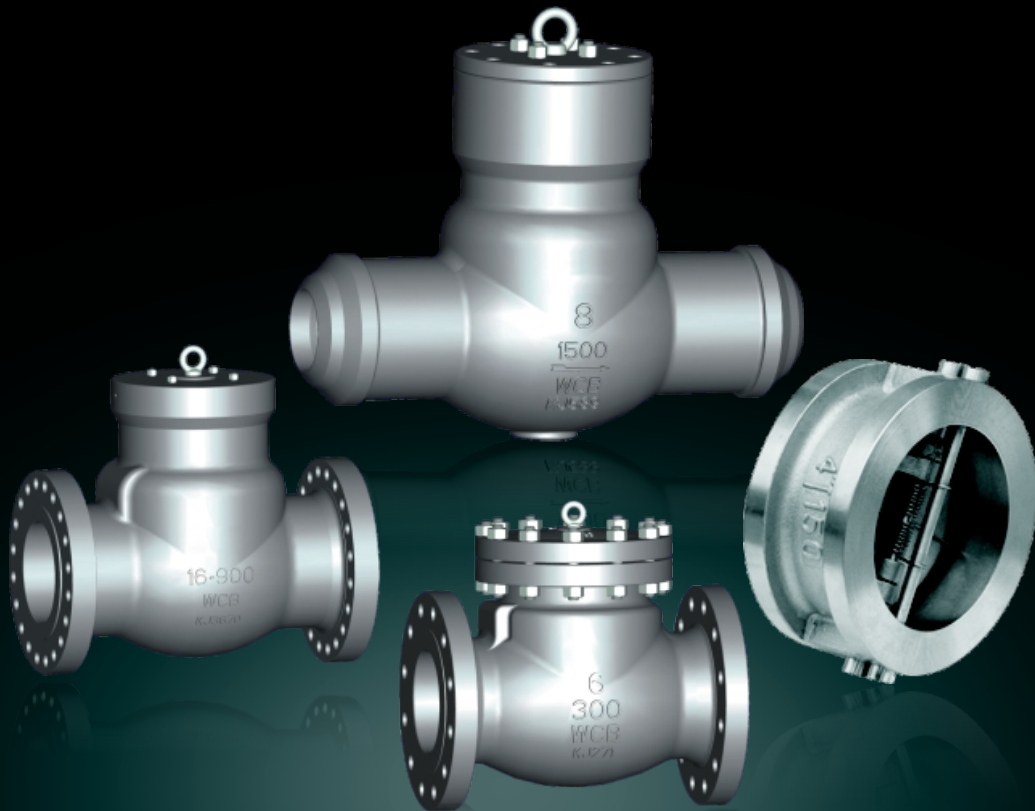

WELCO VALVE



**Cast Steel & Pressure
Seal Swing Check Valves**

www.cnvalveco.com

Design

The cast steel check valves are designed and manufactured to provide maximum service life and dependability. All check valves meet the design requirements of American Petroleum Institute standard API600 & 6D, BS EN 13709 and generally conform to American Society of Mechanical Engineers standard ASME B16.34. Valves are available in a complete range of body/cover materials and trims.

Available Modifications For Cast Steel Valves

Trim changes
End connection modifications
Packing and gasket changes
Operator mounting
Handwheel extensions

Ranges of Materials

Standard body/cover materials include nine grades of carbon, low alloy and stainless steels, for special applications they can be supplied in other grades of alloy and stainless steel, there's a full range of trim materials to match any service optional packing and gasket materials are available for a full range of service conditions.

Pressure equalizing
Customer specified coatings
Weld end bore changes
Oxygen & chlorine cleaning & packaging

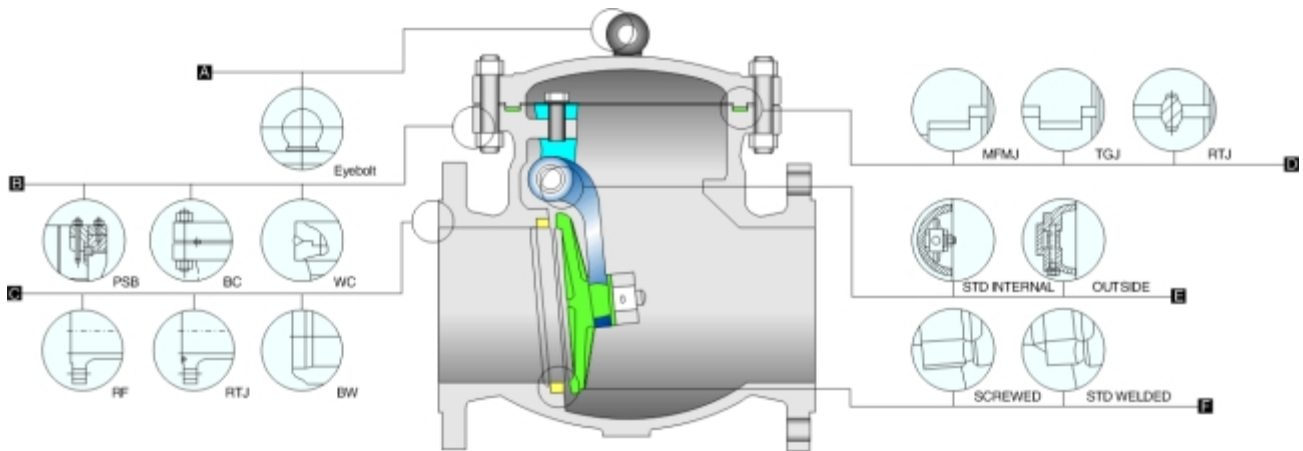

A Eyebolt

For 150Lb–8", 300Lb–8", 600Lb–6", 900Lb/1500Lb/2500Lb–4" & over.

B BC

Bolted cover, welded cover and pressure seal bonnet in services requiring frequent cycling or with high pressure/temperature variations.

C End Connections

A choice of flanged, RTJ flanged or buttwelding end for piping flexibility.

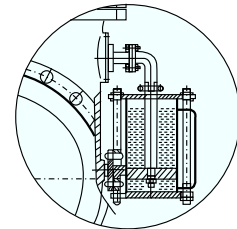

D Body-to-Cover Joint

A male and female joint or tongue and groove joint is used 150Lb to 600Lb valves. Ring joint is used in the body to cover connection in 900Lb & higher rated valves.

E Outside Lever And Weight

All external hinge pin swing check valves 12" and smaller are available with an optional outside lever and weight, internal hinge available with all swing check valves.

F Seat Rings

Separate heavy duty, full ported rings for easy maintenance. Screwed or welded connection into body.

HCU weighted mechanical accumulator

This design can be used to either dampen or assist closing of the check valve disc depending on orientation. by using the hydraulic control unit to buffer action the disc, the valve opens at lower flow rates.

Swing, Cast Steel Check Valve 150Lb/300Lb



Applicable Standards:

- STEEL CHECK VALVES, API 6D
- STEEL CHECK VALVES, ISO 14313
- STEEL VALVES, ASME B16.34
- FACE TO FACE, ASME B16.10
- END FLANGES, ASME B16.5
- BUTTWELDING ENDS, ASME B16.25
- INSPECTION AND TEST, API 598/API 6D

Design descriptions:

- BC, BOLTED COVER
- SWING TYPE, ANTI-ROTATION DISC
- RENEWABLE SEAT RINGS
- NON-PENETRATE DISC SHAFT
- HORIZONTAL OR VERTICAL SERVICE
- FLANGED OR BUTTWELDING ENDS

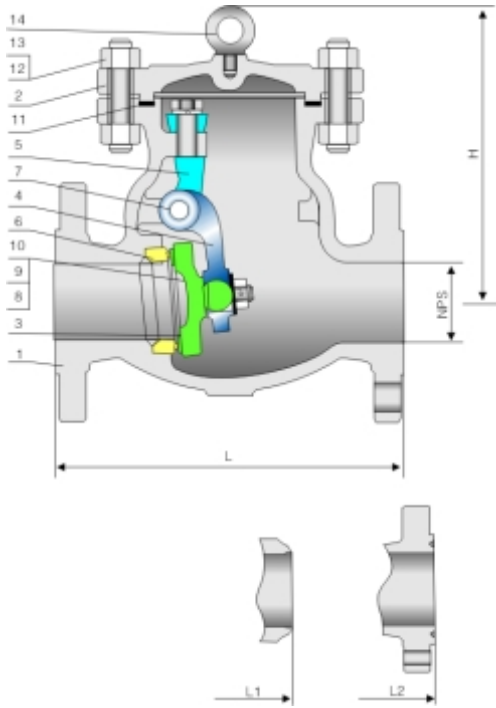

Materials of parts

No	Part Name	ASTM Materials		
		Carbon Steel	1 1/4Cr-1/2Mo	Carbon Steel
1	Body	A216-WCB	A217-WC6	A352-LCB
2	Cover	A216-WCB	A217-WC6	A352-LCB
3	Disc ¹⁾	A105-CR13	A182-F11+HF	A350-LF2+CR13
4	Hinge	A216-WCB	A217-WC6	A352-LCB
5	Fork Part	A216-WCB	A217-WC6	A352-LCB
6	Seat Ring	A105+CR13	A182-F11+HF	A350-LF2+CR13
7	Hinge Pin	A276-420	A276-304	A276-420
8	Disc Washer	Carbon Steel	A276-304	Carbon Steel
9	Disc Nut	Carbon Steel	A194-7	Carbon Steel
10	Disc Nut Pin	Carbon Steel	A276-420	Carbon Steel
11	Gasket	Spiral Wound(Graphite+304)		
12	Stud	A193-B7	A193-B16	A320-L7
13	Stud Nut	A194-2H	A194-7	A194-4
14	Eyebolt ²⁾	Carbon Steel		

Note:1)Cast steel disc for NPS 4" and above.

2)NPS 6" & larger.

3)Disc and seat ring may either be solid facing material or a base material equal to or better than the body/bonnet material with facing as shown.

Dimensional datas of ANSI Class 150Lb

NPS DN	2	2 1/2	3	4	6	8	10	12	14	16	18	20	24	26	28	30	36	in
	50	65	80	100	150	200	250	300	350	400	450	500	600	650	700	750	900	mm
L/L1 (RF/BW)	8.00	8.50	9.50	11.50	14.00	19.50	24.50	27.50	31.00	34.00	38.50	38.50	51.00	51.00	57.00	60.00	77.00	in
	203	216	241	292	356	495	622	699	787	864	978	978	1295	1295	1448	1524	1956	mm
L2 (RTJ)	8.50	9.00	10.00	12.00	14.50	20.00	25.00	28.00	31.50	34.50	39.00	39.00	51.50	-	-	-	-	in
	216	229	254	305	368	508	635	711	800	876	991	991	1308	-	-	-	-	mm
H	6.00	6.50	6.88	8.00	11.50	13.88	15.38	17.00	18.75	20.62	22.88	24.62	34.75	37.00	37.00	38.62	48.00	in
	152	165	175	204	293	353	390	432	475	525	582	627	883	940	940	980	1220	mm
wt(kg)	14	20	25	40	71	118	177	263	353	542	632	855	970	1600	1600	1990	2760	RF/RTJ
	10	12	17	29	57	96	143	227	295	468	552	755	831	1420	1420	1760	2230	BW

Dimensional datas of ANSI Class 300Lb

NPS DN	2	2 1/2	3	4	6	8	10	12	14	16	18	20	24	26	28	30	36	in
	50	65	80	100	150	200	250	300	350	400	450	500	600	650	700	750	900	mm
L/L1 (RF/BW)	10.50	11.50	12.50	14.00	17.50	21.00	24.50	28.00	33.00	34.00	38.50	40.00	53.00	53.00	59.00	62.75	82.00	in
	267	292	318	356	445	533	622	711	838	864	978	1016	1346	1346	1499	1594	2083	mm
L2 (RTJ)	11.12	12.12	13.12	14.62	18.12	21.62	25.12	28.62	33.62	34.62	39.12	40.75	53.88	54.00	60.00	63.75	-	in
	283	308	333	371	460	549	638	727	854	879	994	1035	1368	1372	1524	1619	-	mm
H	6.00	6.50	6.88	8.00	11.50	13.88	15.38	17.00	18.75	20.62	22.88	24.62	34.75	35.88	37.00	38.62	48.00	in
	152	165	175	204	292	353	390	432	475	525	582	627	883	910	940	980	1220	mm
wt(kg)	16	23	29	46	82	136	204	302	405	625	730	985	1115	1465	1840	2290	3180	RF/RTJ
	11	13	18	31	61	103	155	245	315	503	593	812	895	1205	1525	1895	2395	BW



Swing, Cast Steel Check Valve 600Lb/900Lb

Applicable Standards:

- STEEL CHECK VALVES, API 6D
- STEEL CHECK VALVES, ISO14313
- STEEL VALVES, ASME B16.34
- FACE TO FACE, ASME B16.10
- END FLANGES, ASME B16.5
- BUTTWELDING ENDS, ASME B16.25
- INSPECTION AND TEST, API 598/API 6D

Design descriptions:

- BC, BOLTED COVER
- SWING TYPE, ANTI-ROTATION DISC
- RENEWABLE SEAT RINGS
- NON-PENETRATE DISC SHAFT
- HORIZONTAL OR VERTICAL SERVICE
- FLANGED OR BUTTWELDING ENDS

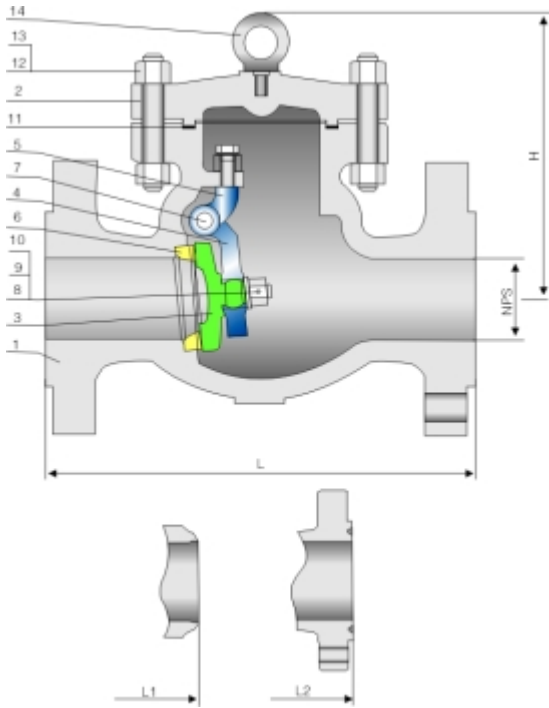

Materials of parts

No	Part Name	ASTM Materials		
		Carbon Steel	1 1/4Cr-1/2Mo	Carbon Steel
1	Body	A216-WCB	A217-WC6	A352-LCB
2	Cover	A216-WCB	A217-WC6	A352-LCB
3	Disc ¹⁾	A216-WCB+CR13	A182-F11+HF	A350-LCB+CR13
4	Hinge	A216-WCB	A217-WC6	A352-LCB
5	Fork Part	A216-WCB	A217-WC6	A352-LCB
6	Seat Ring	A105+CR13	A182-F11+HF	A350-LF2+CR13
7	Hinge Pin	A276-420	A276-304	A276-420
8	Disc Washer	Carbon Steel	A276-304	Carbon Steel
9	Disc Nut	Carbon Steel	A194-7	Carbon Steel
10	Disc Nut Pin	Carbon Steel	A276-420	Carbon Steel
11	Gasket	Spiral Wound(Graphite+304)		
12	Stud	A193-B7	A193-B16	A320-L7
13	Stud Nut	A194-2H	A194-7	A194-4
14	Eyebolt ²⁾	Carbon Steel		

Note:1)NPS 6" & larger.

2)Disc and seat ring may either be solid facing material or a base material equal to or better than the body/bonnet material with facing as shown.

Dimensional datas of ANSI Class 600Lb

NPS DN	2	2 1/2	3	4	6	8	10	12	14	16	18	20	24	in mm
	50 65 80 100 150 200 250 300 350 400 450 500 600	11.50 292	13.00 330	14.00 356	17.00 432	22.00 559	26.00 660	31.00 787	33.00 838	35.00 889	39.00 991	43.00 1092	47.00 1194	
L/L1 (RF/BW)	11.50 292	13.00 330	14.00 356	17.00 432	22.00 559	26.00 660	31.00 787	33.00 838	35.00 889	39.00 991	43.00 1092	47.00 1194	55.00 1397	in mm
L2 (RTJ)	11.62 295	13.12 333	14.12 359	17.12 435	22.12 562	26.12 664	31.12 791	33.12 841	35.12 892	39.12 994	43.12 1095	47.25 1200	55.38 1407	in mm
H	7.50 190	8.00 205	8.75 222	10.00 255	14.50 368	17.50 445	19.25 490	21.38 540	23.38 595	25.75 655	28.75 730	31.00 785	43.50 1105	in mm
wt(kg)	24 16	35 19	44 26	70 44	125 87	207 147	310 220	460 350	615 452	945 720	1105 845	1495 1160	1695 1280	RF/RTJ BW

Dimensional datas of ANSI Class 900Lb

NPS DN	2	2 1/2	3	4	6	8	10	12	14	16	18	20	24	in mm
	50 65 80 100 150 200 250 300 350 400 450 500 600	14.50 368	16.50 419	15.00 381	18.00 457	24.00 610	29.00 737	33.00 838	38.00 965	40.50 1029	44.50 1130	48.00 1219	52.00 1321	
L/L1 (RF/BW)	14.50 368	16.50 419	15.00 381	18.00 457	24.00 610	29.00 737	33.00 838	38.00 965	40.50 1029	44.50 1130	48.00 1219	52.00 1321	- -	in mm
L2 (RTJ)	14.62 371	16.62 422	15.12 384	18.12 460	24.12 613	29.12 740	33.12 841	38.12 968	40.88 1038	44.88 1140	48.50 1232	52.50 1334	- -	in mm
H	9.50 240	10.00 256	11.00 278	12.50 320	18.12 460	22.00 560	24.00 610	26.50 675	29.38 745	32.00 815	33.50 850	38.75 985	- -	in mm
wt(kg)	37 21	54 25	68 34	109 58	195 115	321 194	481 290	711 461	956 597	1468 950	1870 1210	2316 1533	- -	RF/RTJ BW

Swing, Cast Steel Check Valve 1500Lb/2500Lb



Applicable Standards:

- STEEL CHECK VALVES, API 6D
- STEEL CHECK VALVES, ISO14313
- STEEL VALVES, ASME B16.34
- FACE TO FACE, ASME B16.10
- END FLANGES, ASME B16.5
- BUTTWELDING ENDS, ASME B16.25
- INSPECTION AND TEST, API 598/API 6D

Design descriptions:

- BC, BOLTED COVER
- SWING TYPE, ANTI-ROTATION DISC
- RENEWABLE SEAT RINGS
- NON-PENETRATE DISC SHAFT
- HORIZONTAL OR VERTICAL SERVICE
- FLANGED OR BUTTWELDING ENDS

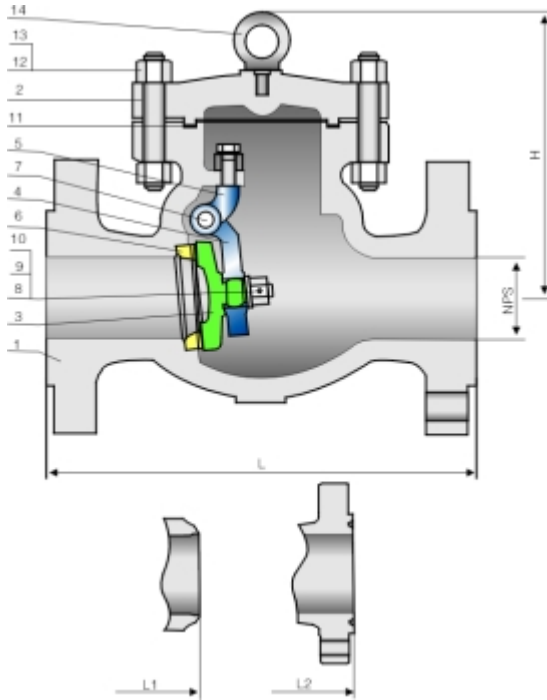

Materials of parts

No	Part Name	ASTM Materials		
		Carbon Steel	1 1/4Cr-1/2Mo	Carbon Steel
1	Body	A216-WCB	A217-WC6	A352-LCB
2	Cover	A216-WCB	A217-WC6	A352-LCB
3	Disc ¹⁾	A216-WCB+CR13	A182-F11+HF	A350-LCB+CR13
4	Hinge	A216-WCB	A217-WC6	A352-LCB
5	Fork Part	A216-WCB	A217-WC6	A352-LCB
6	Seat Ring	A105+CR13	A182-F11+HF	A350-LF2+CR13
7	Hinge Pin	A276-420	A276-304	A276-420
8	Disc Washer	Carbon Steel	A276-304	Carbon Steel
9	Disc Nut	Carbon Steel	A194-7	Carbon Steel
10	Disc Nut Pin	Carbon Steel	A276-420	Carbon Steel
11	Gasket	Spiral Wound(Graphite+304)		
12	Stud	A193-B7	A193-B16	A320-L7
13	Stud Nut	A194-2H	A194-7	A194-4
14	Eyebolt ²⁾	Carbon Steel		

Note:1)NPS 6" & larger.

2)Disc and seat ring may either be solid facing material or a base material equal to or better than the body/bonnet material with facing as shown.

Dimensional datas of ANSI Class1500Lb

NPS	DN	L/L1 (RF/BW)		L2 (RTJ)		H		WT(kg)	
2	50	14.50	368	14.62	371	9.50	240	40	29
2 1/2	65	16.50	419	16.62	422	10.00	256	63	47
3	80	18.50	470	18.62	473	13.00	330	70	49
4	100	21.50	546	21.62	549	14.75	375	115	84
6	150	27.75	705	28.00	711	18.88	480	250	152
8	200	32.75	832	33.12	841	23.50	595	470	310
10	250	39.00	991	39.38	1000	26.00	660	740	470
12	300	44.50	1130	45.12	1146	29.12	740	1100	710
14	350	49.50	1257	50.25	1276	30.88	785	1410	910
16	400	54.50	1384	55.38	1407	32.88	835	1600	1100
in	mm	in	mm	in	mm	in	mm	RF/RTJ	BW

Dimensional datas of ANSI Class2500Lb

NPS	DN	L/L1 (RF/BW)		L2 (RTJ)		H		WT(kg)	
2	50	17.75	451	17.88	454	10.75	275	50	35
2 1/2	65	20.00	508	20.25	514	13.25	335	76	55
3	80	22.75	578	23.00	584	13.75	350	85	68
4	100	26.50	673	26.88	683	15.12	385	165	115
6	150	36.00	914	36.50	927	19.50	495	460	225
8	200	40.25	1022	40.88	1038	24.62	625	900	580
10	250	50.00	1270	50.88	1292	28.00	712	1300	860
12	300	56.00	1422	56.88	1445	35.62	905	1800	1150
14	350	-	-	-	-	-	-	-	-
16	400	-	-	-	-	-	-	-	-
in	mm	in	mm	in	mm	in	mm	mm	mm

Pressure Seal Cast Steel Swing Check Valve 900Lb



Applicable Standards:

- STEEL CHECK VALVES, API 594/API 6D
- STEEL CHECK VALVES, ISO14313
- STEEL VALVES, ASME B16.34
- FACE TO FACE, ASME B16.10
- END FLANGES, ASME B16.5
- INSPECTION AND TEST, API 598/API 6D

Design descriptions:

- PSB, PRESSURE SEAL BONNET
- FLEXIBLE DISC, FULLY GUIDED
- RENEWABLE SEAT RINGS
- FLANGED OR BUTTWELDING ENDS

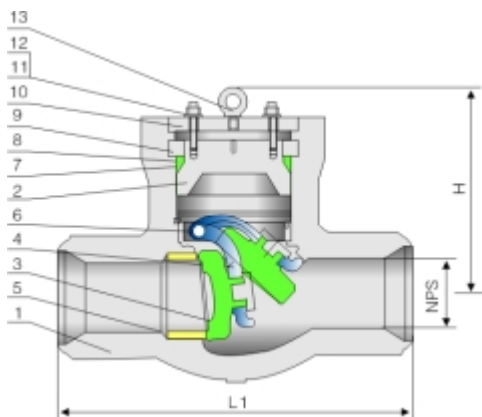

Materials of parts

No	Part Name	ASTM Materials		
		Carbon Steel	1 ¹ / ₄ Cr- ¹ / ₂ Mo	18Cr-9Ni-2Mo
1	Body	A216-WCB	A217-WC6	A351-CF8M
2	Pres. Seal Bonnet	A216-WCB	A217-WC6	A351-CF8M
3	Disc	A105+HF	A182-F11+HF	A351-CF8M+HF
4	Hinge	A216-WCB	A217-WC6	A351-CF8M
5	Seat Ring	A105+HF	A182-F11+HF	A240-316+HF
6	Hinge Pin	A276-420	A276-304	A276-316
7	Bonnet Gasket ¹⁾	Steel Ring	304SS Ring	316SS RING
8	Adapter Ring	Carbon Steel	A276-420	A276-316
9	Retainer	Carbon Steel	A276-420	A276-316
10	Cover	Carbon Steel	Alloy Steel	Stainless Steel
11	Stud	A193-B7	A193-B7	A193-B8M
12	Stud Nut	A194-2H	A194-2H	A194-8M
13	Eyebolt	Carbon Steel		

Note:1) graphite optional

2)disc and seat ring may either be solid facing material or a base material equal to or better than the body/bonnet material with facing as shown.

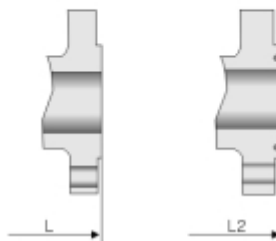

Dimensional datas

NPS DN	2	2 ¹ / ₂	3	4	6	8	10	12	14	16	in
	50	65	80	100	150	200	250	300	350	400	mm
ANSI Class900Lb											
L1 (BW)	8.50	10.00	12.00	14.00	20.00	26.00	31.00	36.00	39.00	43.00	in
	216	254	305	356	508	660	787	914	991	1092	mm
L (RF)	14.50	16.60	15.00	18.00	24.00	29.00	33.00	38.00	40.5	44.5	in
	368	419	381	457	610	737	838	965	1029	1130	mm
L2 (RTJ)	14.62	16.62	15.12	18.12	24.12	29.12	33.12	38.12	40.88	44.88	in
	371	422	384	460	613	740	841	968	1038	1140	mm
H	9.50	9.50	10.00	13.38	15.75	18.12	21.62	24.00	27.00	29.50	in
	240	240	255	340	400	460	550	610	685	750	mm
wt(kg)	22	34	38	71	176	485	761	1125	1345	1490	BW
	44	55	61	116	255	630	940	1433	1710	1820	RF/RTJ



Pressure Seal Cast Steel Swing Check Valve 1500Lb/2500Lb

Applicable Standards:

- STEEL CHECK VALVES, BS EN 13709/API 600
- STEEL VALVES, ASME B16.34
- FACE TO FACE, ASME B16.10
- END FLANGES, ASME B16.5
- BUTTWELDING ENDS, ASME B16.25
- INSPECTION AND TEST, API 598

Design descriptions:

- PSB, PRESSURE SEAL BONNET
- FLEXIBLE DISC, FULLY GUIDED
- RENEWABLE SEAT RINGS
- FLANGED OR BUTTWELDING ENDS

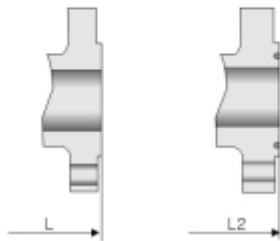
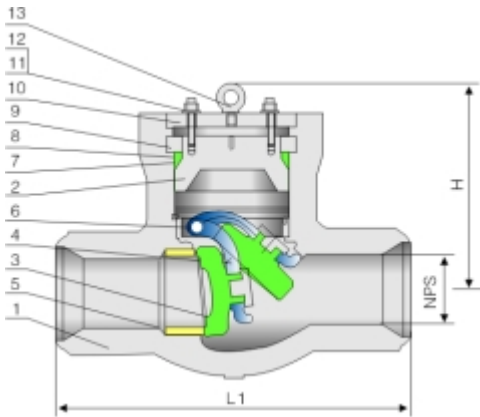

Materials of parts

No	Part Name	ASTM Materials		
		Carbon Steel	1 ¹ / ₄ Cr-1 ¹ / ₂ Mo	18Cr-9Ni-2Mo
1	Body	A216-WCB	A217-WC6	A351-CF8M
2	Pres. Seal Bonnet	A216-WCB	A217-WC6	A351-CF8M
3	Disc	A105+HF	A182-F11+HF	A351-CF8M+HF
4	Hinge	A216-WCB	A217-WC6	A351-CF8M
5	Seat Ring	A105+HF	A182-F11+HF	A240-316+HF
6	Hinge Pin	A276-420	A276-304	A276-316
7	Bonnet Gasket ¹⁾	Steel Ring	304SS Ring	316SS RING
8	Adapter Ring	Carbon Steel	A276-420	A276-316
9	Retainer	Carbon Steel	A276-420	A276-316
10	Cover	Carbon Steel	Alloy Steel	Stainless Steel
11	Bonnet Stud	A193-B7	A193-B7	A193-B8M
12	Bonnet Stud Nut	A194-2H	A194-2H	A194-8M
13	Eyebolt	Carbon Steel		

Note:1) graphite optional

2)disc and seat ring may either be solid facing material or a base material equal to or better than the body/bonnet material with facing as shown.

Dimensional datas

NPS DN	2	2½	3	4	6	8	10	12	14	2	2½	3	4	6	8	10	12	in
	50	65	80	100	150	200	250	300	350	50	65	80	100	150	200	250	300	mm
ANSI Class 1500Lb																		
L1 (BW)	8.50	10.00	12.00	16.00	22.00	28.00	34.00	39.00	42.00	11.00	13.00	14.50	18.00	24.00	30.00	36.00	41.00	in
	216	254	305	406	559	711	864	991	1067	279	330	368	457	610	762	914	1041	mm
L (RF)	14.50	16.50	18.50	21.50	27.75	32.75	39	44.5	49.5	17.75	20.00	22.75	26.50	36.00	40.25	50	56	in
	368	419	470	546	705	832	991	1130	1257	451	508	578	673	914	1022	1270	1422	mm
L2 (RTJ)	14.62	16.62	18.62	21.62	28.00	33.12	39.38	45.12	50.25	17.88	20.50	23.00	26.88	36.50	40.88	50.88	56.88	in
	371	422	473	549	711	842	1000	1146	1276	454	514	584	683	927	1038	1292	1445	mm
H	9.50	9.50	11.88	15.38	18.00	20.62	24.00	27.00	30.00	10.25	10.25	13.75	16.12	18.88	22.38	25.25	32.00	in
	240	240	300	390	455	525	610	685	760	260	260	350	410	480	570	640	815	mm
wt(kg)	22	37	45	78	245	530	815	1213	1555	55	78	95	182	300	630	825	1580	BW
	44	61	110	155	378	675	1160	1710	2315	93	130	170	315	618	1125	1760	2910	RF/RTJ

Applicable Standards:

- STEEL CHECK VALVES, API 594/API 6D
- STEEL CHECK VALVES, ISO 14313
- STEEL VALVES, ASME B16.34
- FACE TO FACE, ASME B16.10
- END FLANGES, ASME B16.5
- INSPECTION AND TEST, API 598/API 6D

Design descriptions:

- ONE PIECE BODY
- BUTTERFLY SWING TYPE
- DUAL-PLATE DISC, LONG-PATTERN
- RENEWABLE SPLIT DISC
- HORIZONTAL OR VERTICAL SERVICE
- WAFER ENDS
- AVAILABLE WITH FLANGED ENDS

Materials of parts

No	Part Name	ASTM Materials		
		Carbon Steel	18Cr-9NiMo	Carbon Steel
1	Body	A216-WCB	A351-CF8M	A352-LCB
2	Plate	A216-WCB+CR13	A351-CF8M+HF	A350-LCB+CR13
3	Stop Pin	A276-420	A276-304	A276-420
4	Back Spring	A313-304	A313-316	A313-304
5	Hinge Pin	A276-420	A276-304	A276-420
6	Eyebolt ²⁾	Carbon Steel		

Note: 1) NPS 8" & larger.

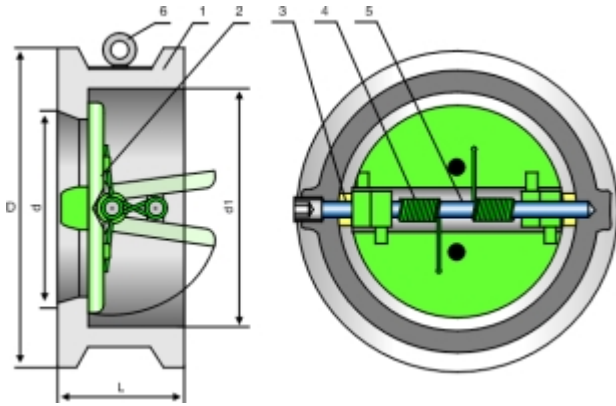

Dimensional datas of ANSI Class 150Lb

NPS DN	2	2½	3	4	6	8	10	12	14	16	18	20	24	in
	50	65	80	100	150	200	250	300	350	400	450	500	600	mm
L	2.38	2.62	2.88	2.88	3.88	5.00	5.75	7.12	7.25	7.50	8.00	8.62	8.75	in
	60	67	73	73	98	127	146	181	184	191	203	219	222	mm
D	4.00	4.88	5.38	6.75	8.62	10.88	13.25	16.00	17.62	20.12	21.50	23.75	28.12	in
	103	122	135	173	220	277	337	407	448	512	547	604	715	mm
d	2.00	2.50	3.25	4.00	6.00	8.00	10.00	12.00	13.75	15.75	17.75	19.75	23.62	in
	51	65	80	102	152	203	254	305	350	400	450	500	600	mm
D1	2.25	2.88	3.50	4.25	6.25	8.25	10.50	12.12	14.00	16.00	18.00	19.88	23.75	in
	56	73	88	108	160	210	266	310	355	405	455	505	605	mm
WT	2	3	4	6	13	25	39	54	80	117	138	163	331	kg

Dimensional datas of ANSI Class 300Lb

NPS DN	2	2½	3	4	6	8	10	12	14	16	18	20	24	in
	50	65	80	100	150	200	250	300	350	400	450	500	600	mm
L	2.38	2.62	2.88	2.88	3.88	5.00	5.75	7.12	8.75	9.12	10.38	11.50	12.50	in
	60	67	73	73	98	127	146	181	222	232	264	292	318	mm
D	4.25	5.00	5.75	7.00	9.88	12.00	14.12	16.50	19.00	21.12	23.38	25.62	30.38	in
	110	128	147	179	249	305	359	420	483	537	594	652	772	mm
d	2.00	2.50	3.00	4.00	6.00	8.00	10.00	12.00	14.00	16.00	18.00	20.00	24.00	in
	51	65	80	102	152	8.25	254	305	350	400	450	500	600	mm
D1	2.25	2.88	3.50	4.25	6.38	203	10.50	12.25	14.00	16.00	18.00	20.00	24.00	in
	58	73	88	108	160	210	266	310	355	405	455	505	608	mm
WT	3	4	6	8	18	31	51	77	117	190	200	265	410	kg

Wafer Cast Steel Check Valve 600Lb/900Lb



Applicable Standards:

- STEEL CHECK VALVES, API 594/API 6D
- STEEL CHECK VALVES, ISO 14313
- STEEL VALVES, ASME B16.34
- FACE TO FACE, ASME B16.10
- END FLANGES, ASME B16.5
- INSPECTION AND TEST, API 598/API 6D

Design descriptions:

- ONE PIECE BODY
- BUTTERFLY SWING TYPE
- DUAL-PLATE DISC, LONG-PATTERN
- RENEWABLE SPLIT DISC
- HORIZONTAL OR VERTICAL SERVICE
- WAFER ENDS
- AVAILABLE WITH FLANGED ENDS

Materials of parts

No	Part Name	ASTM Materials		
		Carbon Steel	18Cr-9NiMo	Carbon Steel
1	Body	A216-WCB	A351-CF8M	A352-LCB
2	Plate	A216-WCB+CR13	A351-CF8M+HF	A350-LCB+CR13
3	Stop Pin	A276-420	A276-304	A276-420
4	Back Spring	A313-304	A313-316	A313-304
5	Hinge Pin	A276-420	A276-304	A276-420
6	Eyebolt ²⁾	Carbon Steel		

Note: 1) NPS 8" & larger.

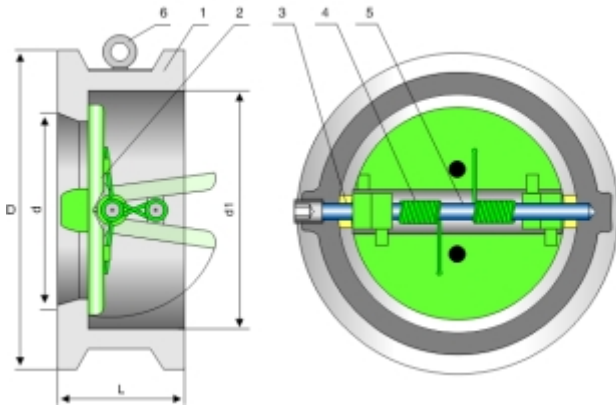

Dimensional datas of ANSI Class 600Lb

NPS DN	2	2½	3	4	6	8	10	12	14	16	in mm
	50	65	80	100	150	200	250	300	350	400	
L	2.38	2.62	2.88	3.12	5.38	6.50	8.38	9.00	10.75	12.00	in
	60	67	73	79	137	165	213	229	273	305	mm
D	4.38	5.00	5.75	7.50	10.38	12.50	15.62	17.88	19.25	22.12	in
	110	128	147	191	264	318	398	455	490	562	mm
d	2.00	2.50	3.00	4.00	6.00	7.88	9.88	12.00	13.25	15.25	in
	51	65	80	102	152	200	250	305	337	387	mm
D1	2.25	2.88	3.50	4.25	6.38	8.38	10.50	12.25	14.00	15.75	in
	58	73	88	108	162	212	266	312	355	400	mm
WT	4	5	8	11	26	55	95	140	223	360	kg

Dimensional datas of ANSI Class 900Lb

NPS DN	2	2½	3	4	6	8	10	12	14	16	in mm
	50	65	80	100	150	200	250	300	350	400	
L	2.75	3.25	3.25	4.00	6.25	8.12	9.50	11.50	-	-	in
	70	83	83	102	159	206	241	292	-	-	mm
D	5.50	6.38	6.50	8.00	11.25	14.00	17.00	19.50	-	-	in
	140	162	165	204	286	356	432	495	-	-	mm
d	2.00	2.50	3.00	4.00	6.00	7.88	9.88	12.00	-	-	in
	51	62	80	102	152	200	250	305	-	-	mm
D1	2.25	2.88	3.50	4.25	6.38	8.38	10.50	12.25	-	-	in
	58	73	88	108	162	212	266	312	-	-	mm
WT	8	11	14	20	42	84	145	220	-	-	kg