

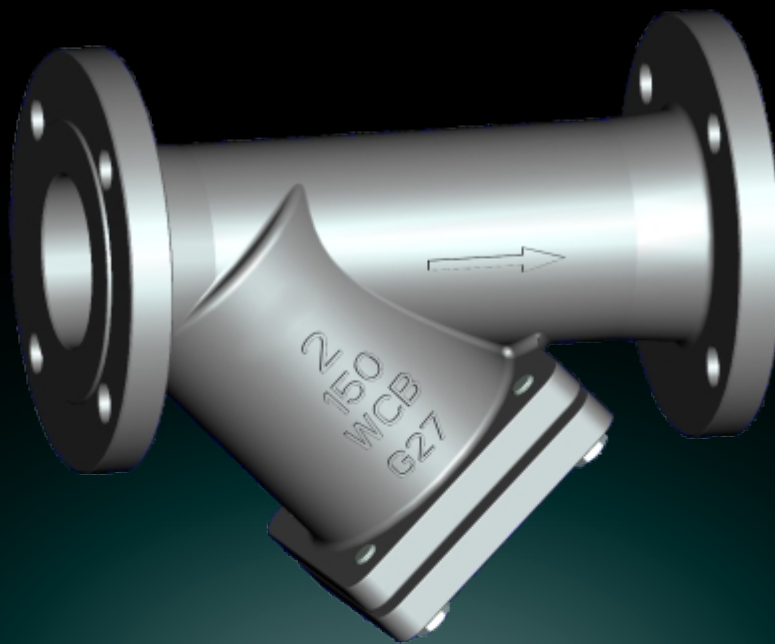

WELCO VALVE



Y-Type and Basket Strainer

www.cnvalveco.com

Applicable Standards:

- STEEL STRAINER, ASME B16.34
- FACE TO FACE, ASME B16.10
- END FLANGES, ASME B16.5
- BUTTWELDING ENDS, ASME B16.25
- INSPECTION AND TEST, API 598

Design descriptions:

- Y-PATTERN TYPE
- BOLTED BONNET CAP WITH DRAIN PLUG
- PERFORATED STAINLESS STEEL SCREEN
- STRAINER DENSITY 100 MESH DESIGN
- FULL RANGE OF STRAINER DENSITY
- RENEWABLE STRAINER DENSITY
- FLANGED OR BUTTWELDING ENDS

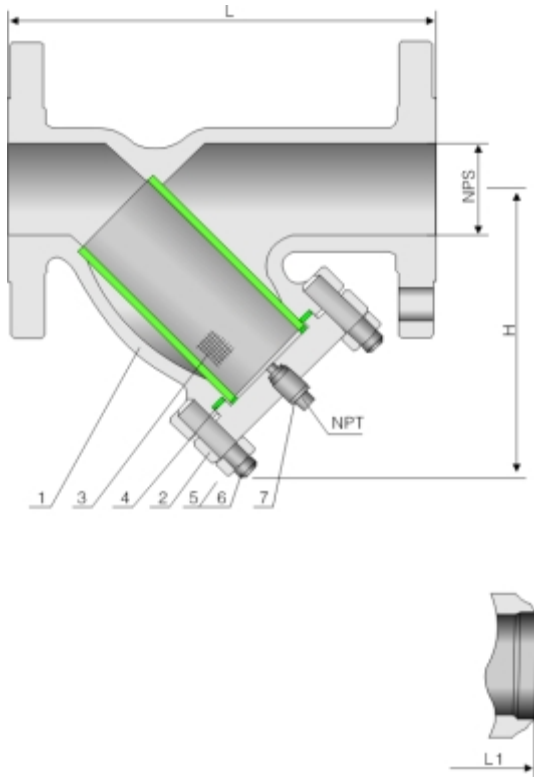

Materials of parts

No	Part Name	ASTM Materials		
		Carbon Steel	18Cr-9Ni-2Mo	Carbon Steel
1	Body	A216-WCB	A351-CF8M	A352-LCB
2	Bonnet Cap	A216-WCB	A351-CF8M	A350-LCB
3	Screen	A240-304	A240-316	A240-304
4	Bonnet Gasket	Graphite+304 ¹⁾	PTFE	Graphite+304 ¹⁾
5	Bonnet Stud	A193-B7	A193-B8	A320-L7
6	Bonnet Stud Nut	A194-2H	A194-8	A194-7
7	Drain Plug	A276-410	A276-316	A276-410

Note:1)spiral wound construction

Percentage of open area

MESH	A SWG	B m/m	C m/m	D %
5	20	0.914	4.166	67.3
10	22	0.711	1.829	51.8
20	28	0.356	0.914	51.8
30	32	0.274	0.572	45.7
40	36	0.193	0.442	48.4
50	37	0.172	0.336	43.6
60	38	0.152	0.271	41.0
80	40	0.122	0.195	37.8
100	42	0.102	0.152	35.8
120	43	0.092	0.119	31.8
150	45 1/2	0.066	0.103	37.1
180	46 1/2	0.053	0.088	38.9
200	47	0.051	0.076	35.8
250	48	0.040	0.062	37.7
300	48	0.039	0.044	27.6

Even the mesh" is same:
open area is not always same
due to the diameter of wire.
The details of wire as follows:

- A: Number of Wire
- B: Diameter of Wire
- C: Width of Opening
- D: Percentage of OPEN AREA

Dimensional datas

NPS	DN	L/L1 (RF/BW)		H		PLUG (NPT)	WT (KG)		L/L1 (RF/BW)		H		PLUG (NPT)	WT (KG)	
ANSI Class 150Lb									ANSI Class 300Lb						
1/2	15	5.50	140	3.38	87	1/8	2.1	0.8	5.50	140	3.38	87	1/8	2.5	1.2
3/4	20	6.00	152	4.12	105	1/2	2.3	1.2	6.00	152	4.12	105	1/2	3.4	1.8
1	25	6.50	165	4.50	114	1/2	3.1	1.4	6.50	165	4.50	114	1/2	4.2	2.6
1 1/2	40	8.00	203	6.12	156	1/2	6.2	3.7	8.00	203	6.12	156	1/2	8.6	4.8
2	50	9.00	229	7.12	181	1/2	9.7	6.7	9.00	229	7.12	181	1/2	11.12	8.2
2 1/2	65	11.00	279	10.25	259	3/4	23.5	16.5	11.00	279	10.25	259	3/4	29	20
3	80	12.50	318	11.50	293	3/4	28	22	12.50	318	11.50	293	3/4	38	27
4	100	14.50	368	12.75	324	3/4	37	28	14.50	368	12.75	324	3/4	57	39
6	150	18.50	470	17.62	448	3/4	67	59	18.50	470	17.62	448	3/4	105	74
8	200	23.50	597	21.00	535	3/4	91	78	23.50	597	21.00	535	3/4	176	131
10	250	26.50	673	27.12	690	1	135	113	26.50	673	27.12	690	1	230	164
12	300	30.50	775	30.75	780	1	168	151	30.50	775	30.75	780	1	360	268
in	mm	in	mm	in	mm	in	RF	BW	in	mm	in	mm	in	RF	BW

Basket Strainer 150Lb/300Lb

Applicable Standards:

DESIGN & MANUFACTURE CONFORM WITH: ASME B16.34
 CONNECTION DIMENTION CONFORMS WITH: ASME B16.5、ASME B16.11、EN 1092
 STRUCTURE AND LENGTH CONFORMS WITH THE TERMS OF THE CONTRACT
 MATERIAL CONFORMS WITH: ISO 5208、API 598

No	Part Name	No	Part Name
1	Body	5	Bottom End Cover
2	Disc	6	Gasket
3	Gasket	7	NPT Screw Plug
4	Seat		

Materials of parts

Body	WCB/CF8M/CF8/CF3M/CF3/CD3MN
Strainer	316/304/316L/304L/S31803
Bonnet	F316/F304/F316L/F304L/F51
Bolt	B7M/B8M/L7M/B16M
Nut	2HM/8M/7M/4M
Gasket	Flexible graphite+304/Flexible graphite+316
Screw Plug	410/316/304/316L/304L/S31803

Materials could be choosed according to customers' requirement & working condition.

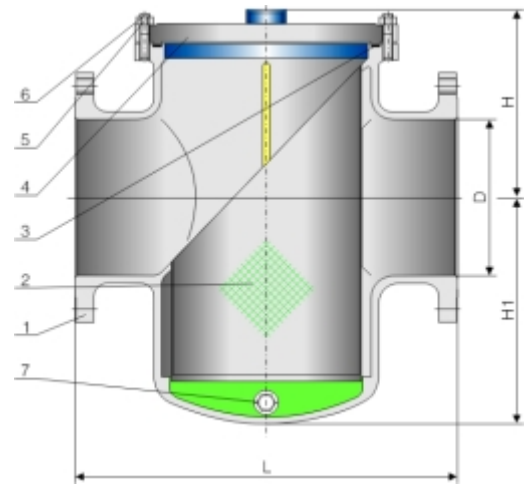

Features and Application:

The strainer is used to improve the purity of products, insure the facilities (compressor pump water) working secure. It's widely used in the production of petrochemical industry material such as weak corrosive, low-temperature. Grains & food, pharmacy.

Dimensional datas

NPS DN	1	1 ¹ / ₄	1 ¹ / ₂	2	2 ¹ / ₂	3	4	6	8	10	12	in mm
	25	32	40	50	65	80	100	150	200	250	300	
ANSI Class 150Lb												
L	180	180	260	260	330	340	400	500	560	660	750	in
H	105	112	130	130	145	150	175	210	260	300	350	mm
H1	165	170	175	175	210	255	300	425	525	600	680	in
WT(kg)	6	7	8	10	14	16	27	55	78	118	158	BW

Dimensional datas

NPS DN	1	1 ¹ / ₄	1 ¹ / ₂	2	2 ¹ / ₂	3	4	6	8	10	12	in mm
	25	32	40	50	65	80	100	150	200	250	300	
ANSI Class 300Lb												
L	180	180	260	260	330	340	400	500	560	660	750	in
H	105	112	130	130	145	150	175	210	260	300	350	mm
H1	165	170	175	175	210	255	300	425	525	600	680	in
WT(kg)	8	9	10	14	20	38	55	90	120	160	216	BW